

VIPER 50mm



AH014R - Pioneer 620mm - Operating Manual

Instruction manual

Warning:

This manual contains important information that will help you maintain and operate your model aircraft in a reliable and safe manner. Please read the instructions and warnings carefully prior to assembly, setup or use.

As this model aircraft is a sophisticated hobby product, it must be flown with safety and common sense in mind, failure in doing so may result in injury or property damage. This product is not intended for use by children without direct adult supervision.

Safety precautions and warnings

As the user, you are solely responsible for the safe operation and maintenance of this product. Follow the directions and warnings listed in this manual, as well as that of supporting equipment (chargers, batteries etc.) and always use common sense.

This is not a toy. Not for children under 14 years of age.

- Always operate your model in an open area away from buildings, cars, traffic or people. Never operate near people-especially children who can wander unpredictably. Never operate in populated areas for any reason, where injury or damage can occur.
- Always keep a safe distance in all directions around your model to avoid collisions or injury. This model is controlled by a radio signal subject to interference from many sources outside your control. Interference can cause momentary loss of control.
- Never catch the aircraft while it is in flight, the structure of the fuselage was not designed and protected for this purpose. Never operate your model in bad weather, including in excessively windy or precipitating conditions.
- Never operate your model with low transmitter batteries.
- Keep your throttle quadrant in its lowest position prior and after every flight. Use the throttle cut function if able. Always use fully charged batteries and move batteries before disassembly.
- Avoid water exposure to all equipment not specifically designed and protected for this purpose.
- Avoid cleaning this product with chemicals.
- Never lick or place any part of your model in your mouth as it could cause serious injury or even death.
- Keep all chemicals, small parts and anything electrical out of the reach of children.

Introduction

Any skill level - Any terrain - Anywhere!

Introducing the Arrows Hobby 620mm Pioneer

Modern beginner pilots are often faced with a daunting task: learning to fly in a limited space without an instructor. For those pilots, Arrows Hobby has the answer! Introducing the Arrows Hobby 620mm Pioneer- a micro bush-plane with BIG performance!

As a proper “all-rounder”, the Pioneer has a classic high-winged tail-dragger design- allowing for predictable handling characteristics.

The pre-installed ESC and flight control system eliminates the need for complicated wiring harnesses and setup.

Switch between stabilized and optimized gyro flight modes and the Pioneer will suit pilots of any skill level.

Oversized wheels and robust EPP foam construction allow for rough-field operations- just plug in the battery, let the gyro calibrate and fly!

With all the exciting aircraft Arrows hobby is releasing, there's no better way to start than the Arrows hobby 620mm Pioneer!

Features

- Oversized power system: 1608-3000kv brushless motor with 7.4V 350mAh 20C battery • Robust landing gear with balloon tires for rough field operations
- Ready to fly package includes everything you need to start flying
- High-lift STOL airframe design
- Integrated receiver and flight controller with stabilized and optimized flight modes
- Programmed from the factory, no setup required
- Robust EPP foam construction

Specifications

Wingspan	620mm
Lenght	416mm
Flying weight	105g
Motor size	1608-KV3000
Wing load	16g/dm ²
Wing area	6.5dm ²
EDF	Ø50mm
ESC	30A
Servo	1.9g (2pcs) • 3.7g (1pc)
Recommended battery	2S 350mAh 20C

Kit contents

Before assembly, please inspect the contents of the kit. The photo below details the contents of the kit with labels. If any parts are missing or defective, please identify the name or part number (refer to the spare parts list near the end of the manual) then contact your local shop.

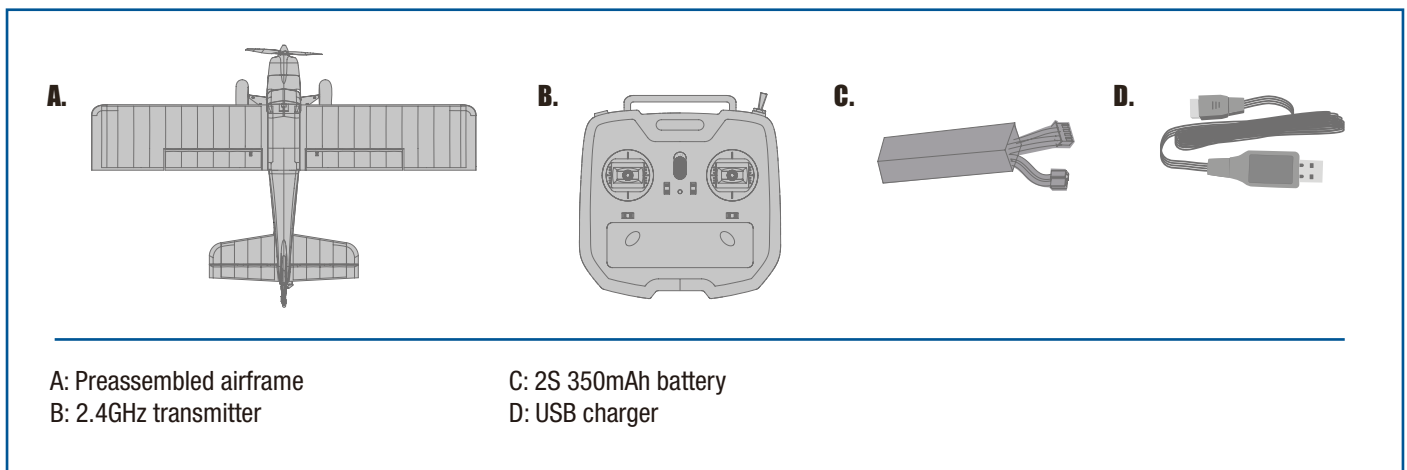

BATTERY INSTALLATION

1. Remove the battery cover.
2. Remove the hook and loop tape from the fuselage. Apply the looped surface to the battery.
3. Install the battery into the fuselage- securing it with the preinstalled battery straps.

Note: The weight of each battery may vary due to different manufacturing techniques. Move the battery fore or aft to achieve the optimal center of gravity.

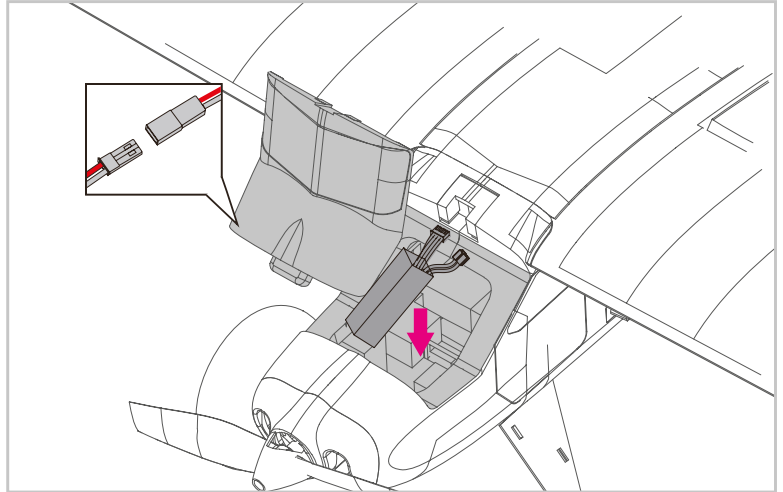

Receiver diagram

The cables from the servo connector board should be connected to your receiver in the order shown. Note that the LEDs can be powered by any spare channel on the receiver. Tuck the wire leads into the recessed cavity towards the rear of the battery hatch.

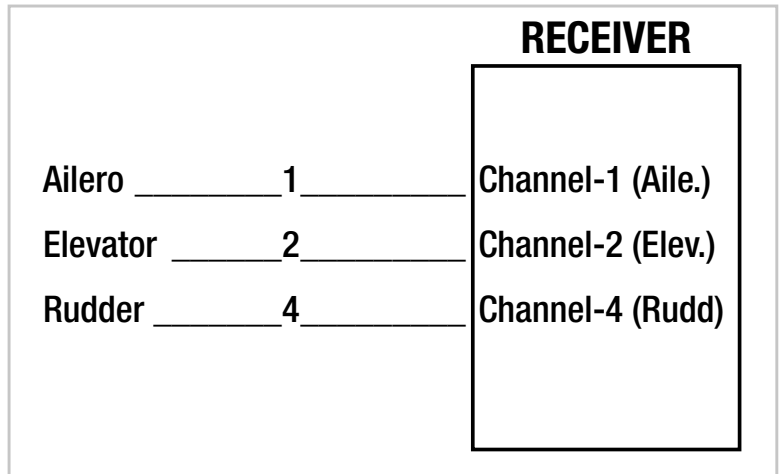

PREFLIGHT CHECK

Important ESC and model information

1. The ESC included with the model has a safe start. If the motor battery is connected to the ESC and the throttle stick is not in the low throttle or off position, the motor will not start until the throttle stick is moved to the low throttle or off position. Once the throttle stick is moved to the low throttle or off position, the motor will emit a series of beeps. Several beeps with the same tune means the ESC has detected the cells of the battery. The count of the beeps equals the cells of the battery. The motor is now armed and will start when the throttle is moved.
2. The motor and ESC come pre-connected and the motor rotation should be correct. If for any reason the motor is rotating in the wrong direction, simply reverse two of the three motor wires to change the direction of rotation.
3. The motor has an optional brake setting. The ESC comes with brake switched off and we recommend that the model be flown with the brake off. However, the brake could be accidentally switched on if the motor battery is connected to the ESC while the throttle stick is set at full throttle. To switch the brake off, move the throttle stick to full throttle and plug in the motor battery. The motor will beep one time. Move the throttle stick to low throttle or the off position. The motor is ready to run and the brake will be switched off.
4. Battery Selection and Installation. We recommend the 2S 350mAh 20C Li-Po Li-Po battery. If using another battery, the battery must be at least a 2S 350mAh 20C Li-Po battery. Your battery should be approximately the same capacity, dimension and weight as the 2S 350mAh 20C Li-Po battery to fit the fuselage without changing the center of gravity significantly.

PREFLIGHT CHECK

Transmitter and Model setup

After assembly and prior to your first flight, make sure all control surfaces respond correctly to your transmitter by referring to the diagram below.

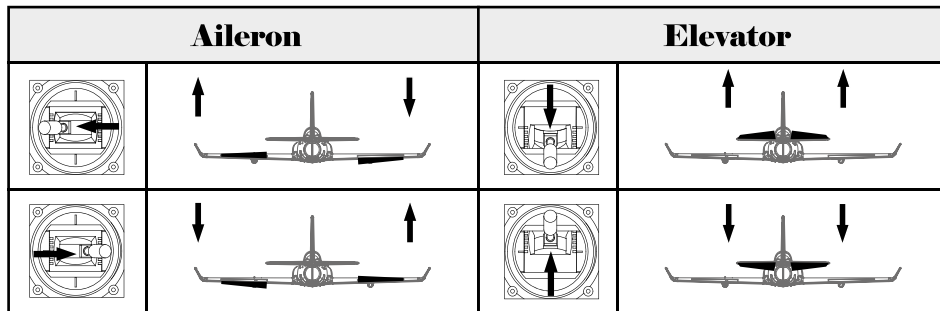

Control setup

The suggested control throw setting for the model are as follows (dual rate setting):

Tip: The maiden flight should always be flown using low rates, fly the aircraft until you are familiar with its characteristics prior to trying high rates. Make sure the aircraft is flying at altitude and adequate velocity prior to using high rates, as the aircraft will be sensitive to control inputs with the larger control surface movements.

	High rate	Low Rate
Elevator	12mm Up/Down	10mm Up/Down
Aileron	12mm Up/Down	10mm Up/Down
Rudder	10mm Left/Right	8mm Left/Right

CENTRE OF GRAVITY

Finding the correct center of gravity is critical in ensuring that the aircraft performs in a stable and responsive manner. Please adjust the weight distribution so the aircraft balances in the range stated on the diagram.

- Depending on the capacity and weight of your chosen flight batteries, move the battery forward or backward to adjust the center of gravity.
- If you cannot obtain the recommended CG by moving the battery to a suitable location, you can also install a counterweight to achieve correct CG. However, with the recommended battery size, a counterweight is not required. We recommend flying without unnecessary counterweight.

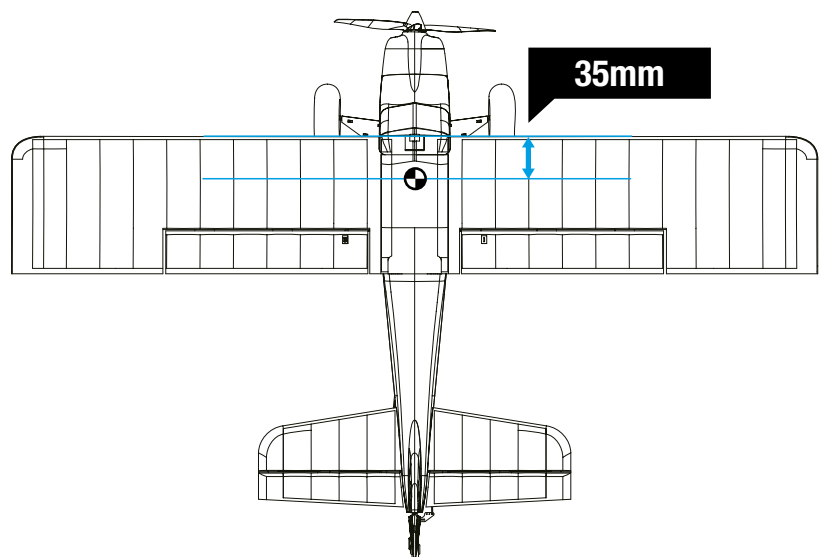

BEFORE FLYING THE MODEL

Find a suitable flying site

Find a flying site clear of buildings, trees, power lines and other obstructions. Until you know how much area will be required and have mastered flying your plane in confined spaces, choose a site which is at least the size of two to three football fields - a flying field specifically for R/C planes is best. Never fly near people - especially children, who can wander unpredictably.

Performing a range check

A radio range check should be performed prior to the first flight of the day. This test may assist you in detecting electronic problems that may lead to a loss of control- problems such as low transmitter batteries, defective or damaged radio components or radio interference. This usually requires an assistant and should be done at the flying site.

Transmitter ON first

Always turn your transmitter on first. Install a fully charged battery in the battery bay, then connect it to the ESC. In this process, make sure that the throttle cut functionality is on, and that the throttle stick is secured in its lowest position- other-wise, the propeller/fan will engage and possibly cause bodily harm.

Note: Please refer to your transmitter manual that came with your radio control system to perform a ground range check. If the controls are not working correctly or if anything seems wrong, do not fly the model until you correct the problem. Make certain all the servo wires are securely connected to the receiver and the transmitter batteries have a good connection.

Monitor your flight time

Monitor and limit your flight time using a timer (such as a stopwatch or on the transmitter, if available). As modern Lithium Polymer batteries are not designed to discharge completely, when the battery runs low, the ESC will lower then completely cut the power to the motors to protect the battery. Often (but not always) power can be briefly restored after the motor cuts off by holding the throttle stick all the way down for a few seconds. To avoid an unexpected dead-stick landing on your first flight, set your timer to a conservative 4 minutes. When your alarm sounds you should land right away.

FLIGHT TIPS

Take off

Point the aircraft into the wind while slowly applying power until the aircraft starts to track straight, use the rudder when necessary. When the aircraft reaches takeoff speed, ease back on the elevator stick until the aircraft is climbing at a constant rate without decelerating. Climbing at too steep of an angle at the relatively low speeds of a takeoff-climb may result in an aerodynamic stall.

Flying

Always choose a wide-open space for flying your plane. It is ideal for you to fly at a sanctioned flying field. If you are not flying at an approved site always avoid flying near houses, trees, wires and buildings. You should also be careful to avoid flying in areas where there are many people, such as busy parks, schoolyards, or soccer fields. Consult laws and ordinances before choosing a location to fly your aircraft. After takeoff, gain some altitude. Climb to a safe height before trying technical manoeuvres.

Landing

Land the aircraft when you start to feel sluggish motor response. If using a transmitter with a timer, set the timer so you have enough flight time to make several landing approaches. The model's three point landing gear allows the model to land on hard surfaces. Align model directly into the wind and fly down to the ground. Fly the airplane down to the ground using 1/4-1/3 throttle to keep enough energy for proper flare. Before the model touches down, always fully decrease the throttle to avoid damaging the propeller or other components. The key to a great landing is to manage the power and elevator all the way to the ground and set down lightly on the main landing gear. With some practice, you will be able to set the aircraft gently on its main gear and hold it that way until the speed reduces enough where the nose wheel (tricycle landing gear aircraft) or tail wheel (tail draggers) settles onto the ground.

Maintenance

Repairs to the foam should be made with foam safe adhesives such as hot glue, foam safe CA, and 5min epoxy. When parts are not repairable, see the spare parts list for ordering by item number.

Always check to make sure all screws on the aircraft are tightened. Pay special attention to make sure the spinner is firmly in place before every flight.

TROUBLESHOOTING

PROBLEM	POSSIBLE CAUSE	SOLUTION
Aircraft will not respond to the throttle but responds to other controls.	<ul style="list-style-type: none"> • ESC is not armed. • Throttle channel is reversed. 	<ul style="list-style-type: none"> • Lower throttle stick and throttle trim to lowest settings. • Reverse throttle channel on transmitter.
Excessive vibration or propeller noise.	<ul style="list-style-type: none"> • Damaged spinner, propeller, motor or motor mount. • Loose propeller and spinner parts. Propeller installed backwards. 	<ul style="list-style-type: none"> • Replace damaged parts. • Tighten parts for propeller adapter, propeller and spinner. • Remove and install propeller correctly.
Reduced flight time or aircraft underpowered.	<ul style="list-style-type: none"> • Flight battery charge is low. Propeller installed backward. Flight battery damaged. 	<ul style="list-style-type: none"> • Completely recharge flight battery. • Replace flight battery and follow flight battery instructions.
Control surfaces unresponsive or sluggish.	<ul style="list-style-type: none"> • Control surface, control horn, linkage or servo damage. • Wire damaged or connections loose. 	<ul style="list-style-type: none"> • Replace or repair damaged parts and adjust controls. • Do a check of connections for loose wiring.
Controls reversed.	<ul style="list-style-type: none"> • Channels are reversed in the transmitter. 	<ul style="list-style-type: none"> • Do the control direction test and adjust controls for aircraft and transmitter.
Motor loses power Motor power pulses then motor loses power.	<ul style="list-style-type: none"> • Damage to motor, or battery. • Loss of power to aircraft. • ESC uses default soft Low Voltage Cutoff(LVC). 	<ul style="list-style-type: none"> • Do a check of batteries, transmitter, receiver, ESC, motor and wiring for damage(replace as needed). • Land aircraft immediately and recharge flight battery.
LED on receiver flashes slowly.	<ul style="list-style-type: none"> • Power loss to receiver. 	<ul style="list-style-type: none"> • Check connection from ESC to receiver. • Check servos for damage. • Check linkages for binding.

SPARE PARTS LIST

AHAM101	Fuselage	AHTX01	(Works only with AHTX01)
AHAM102	Mainwing set	AHBAT01	Transmitter(Works only with AHRX01)
AHAM103	Horizontal stabilizer	AHCHR01	7.4V 350mah 20C Battery (JST plug)
AHAM104	Battery Door		Charger
AHAM105	Mainwing supporting bar set		
AHAM106	Steel set		
AHAM107	Cowl		
AHAM108	Spinner		
AHAM109	Main landing gear set		
AHAM110	Rear landing gear set		
AHAM111	Decal set		
AHPROP010	Propeller		
AHKV3000	1608-KV3000 Motor		
AH1.9GP	1.9g servo positive		
AH3.7GP	3.7g servo positive		
AHRX01	Receiver (three-in-one integrated)		



Arrows RC is distributed by Pro Models

Geelseweg 80 • 2250 Olen • Belgium • info@promodels.be